

ComfoUnit Whole House Heat Recovery Ventilation





Integrated, 'eco-home living' solutions for the comfort and health of you and your home.

Zehnder Comfosystems offer a collection of indoor climate solutions which are suitable for every home. They are designed to provide efficient and economical comfort, supplying heating, cooling, ventilation and hot water, delivering comfort on every level whilst helping to reduce energy consumption for the homeowner.

ComfoUnit heat recovery ventilation systems provide whole house ventilation and utilise energy efficient, recoverable technology. The range of units provide excellent indoor air quality for homes, saving energy and providing whole house, everyday comfort.

For Eco Home Living.

ComfoUnit – How does a whole house ventilation system with heat recovery work?	3 – 4
ComfoUnit – What are the benefits of a whole house ventilation system with heat recovery?	5 – 6
ComfoUnit – Range Overview	7 – 8
ComfoUnit – The Range – CA200	9
ComfoUnit – The Range – CA350	10
ComfoUnit – The Range – CA550	11
ComfoUnit – The Range – ComfoCool	12
Zehnder Comfosystems – Services and Support	13

ComfoUnit – How does a whole house ventilation system with heat recovery work?

Modern, eco-buildings are constructed to rigorously high standards. These air tight buildings require premium ventilation systems in order to maintain excellent indoor air quality. The difference between choosing another manufacturer's ventilation system and choosing a Zehnder Comfosystems whole house heat recovery ventilation system however is marked. Comfosystems' innovative, high quality units are SAP Q eligible and the range includes PassivHaus accredited products. A full range of units capable of ventilating a whole spectrum of property sizes negating the complication and expense of using multiple units in larger dwellings can be supplied.

Comfosystems are also differentiated from their competitors because they can offer a wide portfolio of complimentary products designed to be effortlessly integrated into one functioning and effective system. Not only can you choose our whole house heat recovery ventilation units, you can also select a ground source heat exchanger, enthalpy heat exchanger and ComfoFresh air distribution system to augment and improve the efficiency, health and comfort benefits of your installation. With Zehnder Comfosystems, these products have all been designed under one roof with the intention of modularity thus ensuring that performance, functionality and ease of installation are not compromised.

A whole house ventilation unit with heat recovery works by simultaneously extracting air from wet rooms (kitchens and bathrooms) and supplying fresh, filtered air to habitable rooms. The supply air is drawn in from the outside and tempered using heat recovered from the warmer extracted air. Not only is this methodology energy efficient – up to 90% of heat which would otherwise have been lost through ventilation can now be recovered – but it also conveys the twin benefits of health and comfort to the end user.

1 2 There are three types of induction system which can be used with the ComfoAir system;

- Fresh air is drawn in from outside via a wall vent
- Fresh air is drawn in from outside via an air intake tower (method as shown in diagram) and linked to the home using a ground loop. The air is pre heated or pre cooled by the temperature of the earth (ComfoFond option)
- A ground loop containing a brine solution is installed below the ground's surface. The brine in the ground loop is pre heated or pre cooled by the temperature of the earth (ComfoFond L option)

For more information on ground source heat exchangers, please see the Zehnder Comfosystems ComfoFond brochure.

3 The ComfoAir heat recovery ventilation system works to extract air from wet rooms (kitchens and bathrooms) running around the clock. It extracts the heat energy which would otherwise have been lost during the extract process and transfers this to the fresh, filtered supply air which is being drawn in from the outside.

In some instances, the environment within an air tight home can become too dry for comfort. It is possible to upgrade the heat exchanger on selected units to the Zehnder Enthalpy Heat Exchanger. Not only does this product extract heat from extracted air it also extracts water vapour which can then be used to regulate the humidity of supply air to ensure it is optimised for comfort with no loss in performance.

4 The ComfoAir system is connected to a ducted air distribution system which delivers fresh, filtered air to habitable rooms. This air has been tempered by heat recovered from extracted air.

The ventilation rate – the amount of air which is either extracted or supplied – can easily be adjusted on a room by room basis to ensure that the system performs at its optimum.

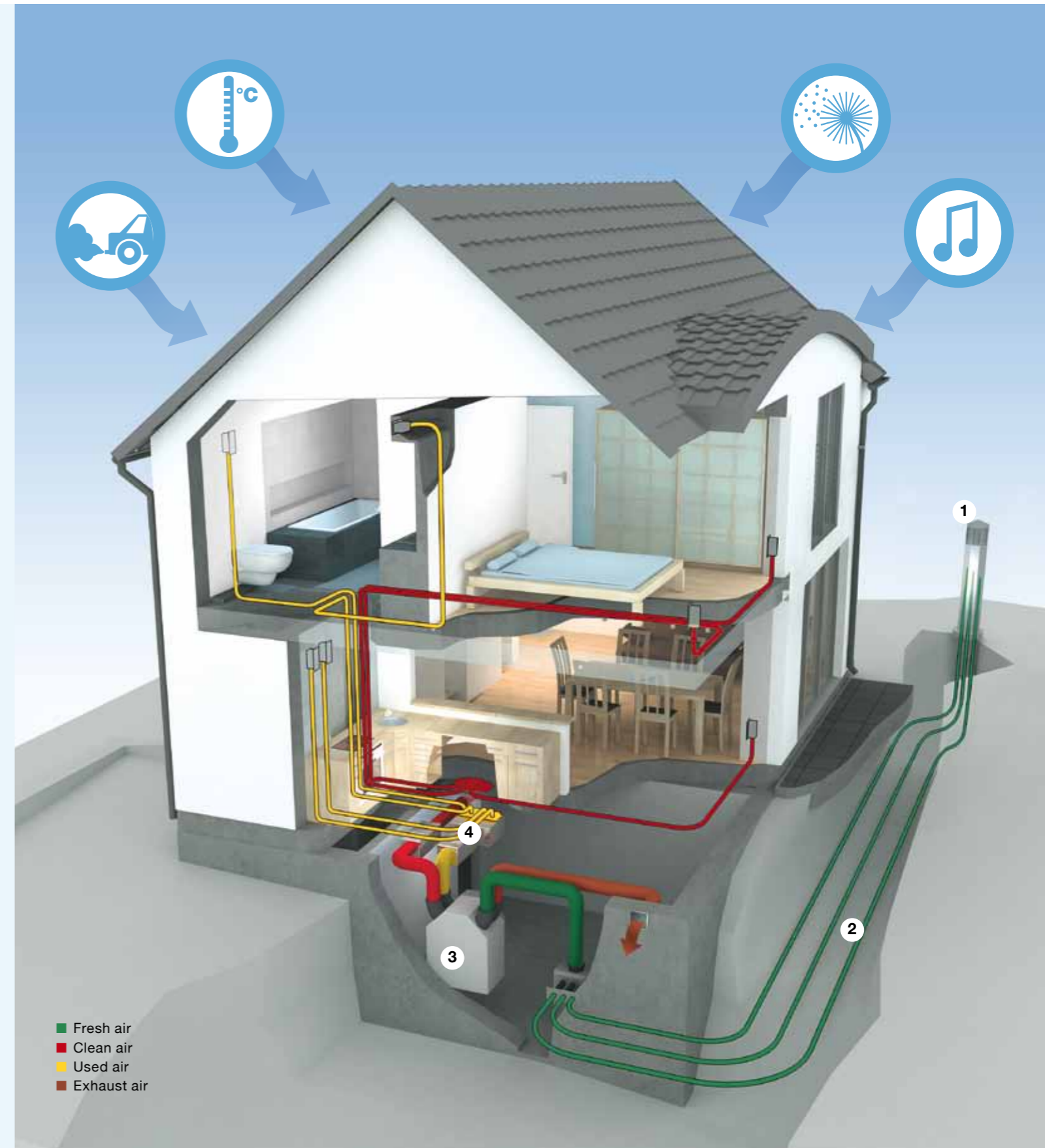

ComfoUnit – What are the benefits of a whole house ventilation system with heat recovery?



Energy Efficiency

Building services cannot be supplied to a home without an input of energy. The increasing cost of this energy can be measured in both environmental and fiscal terms as traditional means of energy generation draw on our finite resources of fossil fuels. ComfoAir products recover energy which would otherwise have been lost to the atmosphere if traditional ventilation methods had been employed.

Improvements to the build standards have resulted in materials and construction methods becoming increasingly air tight. This has meant that a well designed ventilation system has become imperative in order to maintain air quality with a heat recovery ventilation system offering the most energy efficient, environmentally credible way of achieving this.

Whole house heat recovery ventilation technology can recoup up to 90% of the heat which would otherwise have been lost through extracted air. By using Zehnder Comfosystems products instead of more traditional approaches to ventilation, you can make a valuable contribution to reducing your home's carbon emissions.



Health

Advances in construction materials and methods to make our homes more energy efficient and reduce their running costs, mean that we potentially pay the penalty with health related issues. Poor ventilation and air quality can lead to an increased incidence of asthma and allergic symptoms due to sensitivity to allergens such as dust mites, VOCs, pollen and mould. By improving ventilation the concentration of these allergens can be reduced. In addition to improving air quality, our products also contain replaceable filters which are designed to remove airborne particles such as pollen to further ensure that the home is a more comfortable and allergen free environment.



Comfort

On average we spend approximately 70% of our time inside, therefore the provision of a comfortable environment is very important to both our health and our sense of well-being. ComfoAir heat recovery ventilation products simultaneously extract moist, stale air from bathrooms and kitchens and supply tempered air to habitable rooms around the clock. Air is supplied at a low velocity ensuring that fresh, clean air does not create drafts around the home.

All products are installed away from the visible interior of the house – probably in a loft space or plant room – so as the only noticeable components of the system are aesthetically designed air inlets or exhaust grilles. As well as minimizing noise associated with the systems' operation, this also helps to reduce ingress of noise from the outside of your dwelling. The ventilation systems are balanced and so do not require any background ventilation which puts additional holes in the fabric of the building and potentially allows exterior noise to pollute your home.

The systems are simple to control and give home owners the peace of mind that their low energy eco home will be comfortable and healthy all year round.



Product	ComfoAir 200			ComfoAir 350			ComfoAir 550		
	CA200R CA200L ComfoAir 200 Right or Left Hand Installation Model	CA200R Luxe CA200L Luxe ComfoAir 200 Right or Left Hand Installation Model	CA200R Luxe PH CA200L Luxe PH ComfoAir 200 Right or Left Hand Installation Model – with built in pre-heater	CA350R CA350L ComfoAir 350 Right or Left Hand Installation Model	CA350R Luxe CA350L Luxe ComfoAir 350 Right or Left Hand Installation Model – compatible for Luxe control panel	CA350R Luxe PH CA350L Luxe PH ComfoAir 350 Right or Left Hand Installation Model – compatible for Luxe control panel with built in pre-heater	CA550R CA550L ComfoAir 550 Right or Left Hand Installation Model	CA550R Luxe CA550L Luxe ComfoAir 550 Right or Left Hand Installation Model – compatible for Luxe control panel	CA550R Luxe PH CA550L Luxe PH ComfoAir 550 Right or Left Hand Installation Model – compatible for Luxe control panel with built in pre-heater

Airflow Rates	Max. 200m ³ /hr	Max. 200m ³ /hr	Max. 200m ³ /hr	Max. 350m ³ /hr	Max. 350m ³ /hr	Max. 350m ³ /hr	Max. 550m ³ /hr	Max. 550m ³ /hr	Max. 550m ³ /hr
Heat Recovery Efficiency	90%	90%	90%	90%	90%	90%	90%	90%	90%
SFP (Specific Fan Power)*	0.90 W/l/s	0.90 W/l/s	0.90 W/l/s	0.69 W/l/s	0.69 W/l/s	0.69 W/l/s	0.78 W/l/s	0.78 W/l/s	0.78 W/l/s
Summer By Pass	✓	✓	✓	✓	✓	✓	✓	✓	✓
Preheater			✓			✓			✓
Filters	Grade G4	Grade G4	Grade G4	Grade G4	Grade G4	Grade G4	Grade G4	Grade G4	Grade G4

*Lowest performance point presented. Visit www.sap-appendixq.org.uk for full test information.

Control Options

Integral LCD Display on Unit	✓			✓			✓		
2-3 Position Switch	✓	✓	✓	✓	✓	✓	✓	✓	✓
LCD Display (CCEase)		✓	✓		✓	✓		✓	✓
RFZ Radio Frequency (additional switches only)		✓	✓		✓	✓		✓	✓
Luxe Touch Screen Control Panel					✓	✓		✓	✓

Add-on Options

Artic Cooling					✓	✓		✓	✓
Enthalpy Heat Exchanger				✓	✓	✓	✓	✓	✓
ComfoFond-L					✓	✓		✓	✓
ComfoFond	✓	✓	✓	✓	✓	✓	✓	✓	✓

ComfoUnit – The Range

CA200 ComfoAir 200 Model

- Heat recovery performance up to 90%
- Ultra efficient EC motors offer distinct energy savings
- Summer Bypass
- Grade G4 Dust Filters
- Frost Protection
- Simple maintenance for both dust filters and heat exchanger

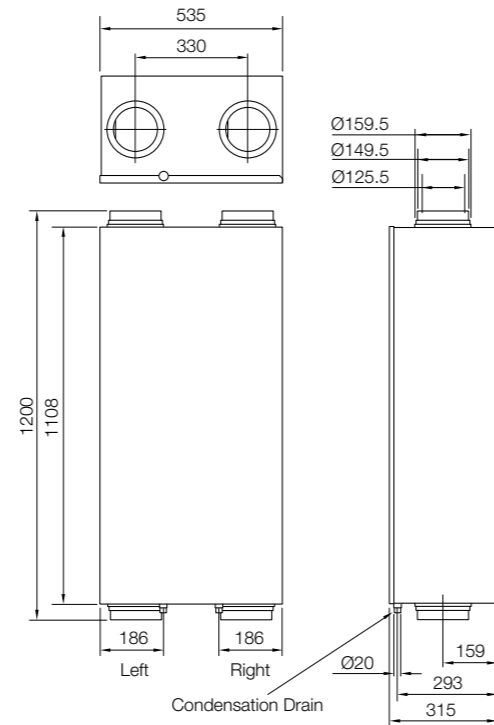
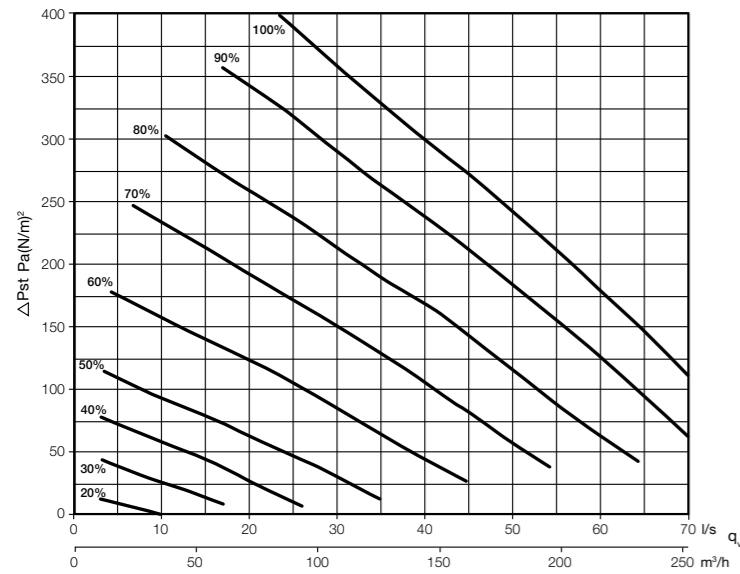

Ancillaries

GD8 Ducting



Flat51 Ducting



Product Specification	
Max House Size EST	110m ² /264m ³
Case Size in mm (W x D x H)	535 x 1200 x 315
Weight	30kg
Airflow in free air (l/s)	6 – 70
Noise dB(A)	36 - 73
Power (Watts)	9 – 143
Specific Fan Power (W/l/s)	0.90 – 1.36 (0.90)
Spigot Size ID	125.5mm
Filters	G4 standard
Heat efficiency	90 – 93 (90%)
Summer bypass/Frost protection	Yes/Yes
Pre-heater	Optional
Condensate Drain	20mm

Electrical Specification	
Consumption	230V ~ 50Hz Class I Trickle – 17W, Medium – 30W, Boost – 68W
Wiring	Must comply with IEE or local wiring regulations
Fuse	3 amp (when fan is supplied from a 6A lighting circuit no local fuse is required)

CA350 ComfoAir 350 Model

Features

- Heat recovery performance up to 85%
- Ultra efficient EC motors offer distinct energy savings
- Summer Bypass
- Grade G4 Dust Filters
- Simple maintenance for both dust filters and heat exchanger

Performance

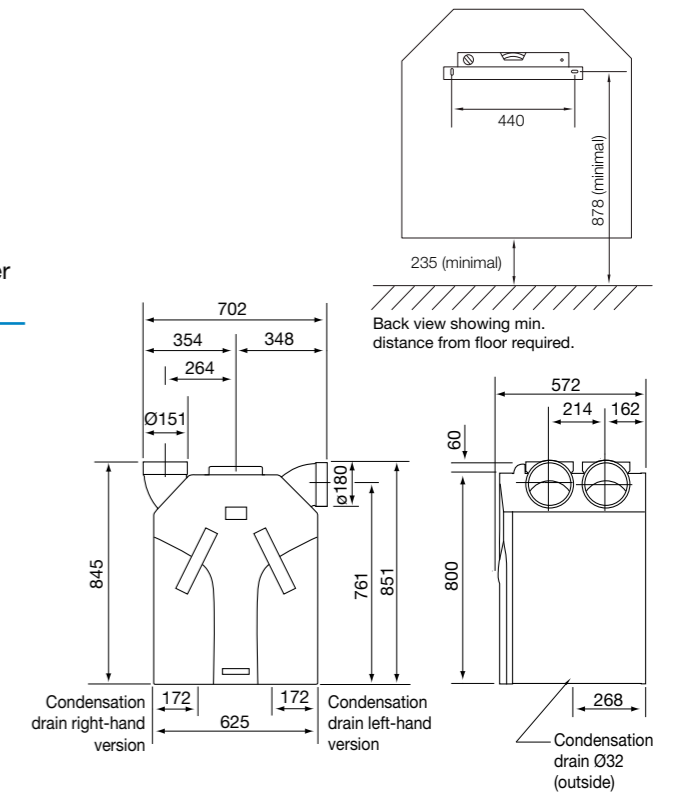
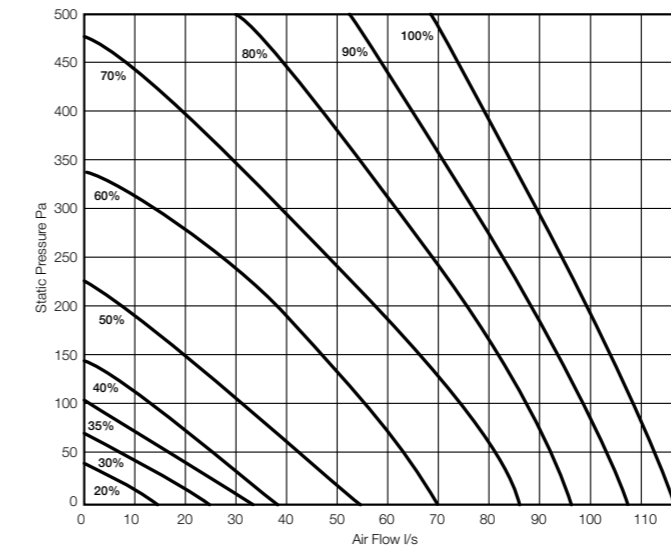

Ancillaries

GD8 Ducting



Flat51 Ducting



Product Specification	
Max House Size EST	200m ² /480m ³
Case Size in mm (W x D x H)	652 x 572 x 851
Weight	39kg
Airflow in free air (l/s)	28 – 97
Noise dB(A)	36.7 – 60.8
Power (Watts)	6 – 243
Specific Fan Power (W/l/s)	0.69 – 1.00 (0.70)
Spigot Size ID	160mm
Filters	G4 standard/EU7/F7 filters optional
Heat efficiency	86 – 88 (85%)
Summer bypass/Frost protection	Yes/Yes
Enthalpy Heat Exchanger	Optional
Pre-heater	Optional
Condensate Drain	32mm

Electrical Specification	
Consumption	230V ~ 50Hz Class I Trickle – 21W, Medium – 44W, Boost – 105W
Wiring	Must comply with IEE or local wiring regulations
Fuse	Standard Model – 3 amp (when fan is supplied from a 6A lighting circuit no local fuse is required). Luxe Model – 6 amp.

ComfoUnit – The Range

CA550 ComfoAir 550 Model

Features

- Heat recovery performance up to 85%
- Ultra efficient EC motors offer distinct energy savings
- Summer Bypass
- Grade G4 Dust Filters
- Simple maintenance for both dust filters and heat exchanger

Performance

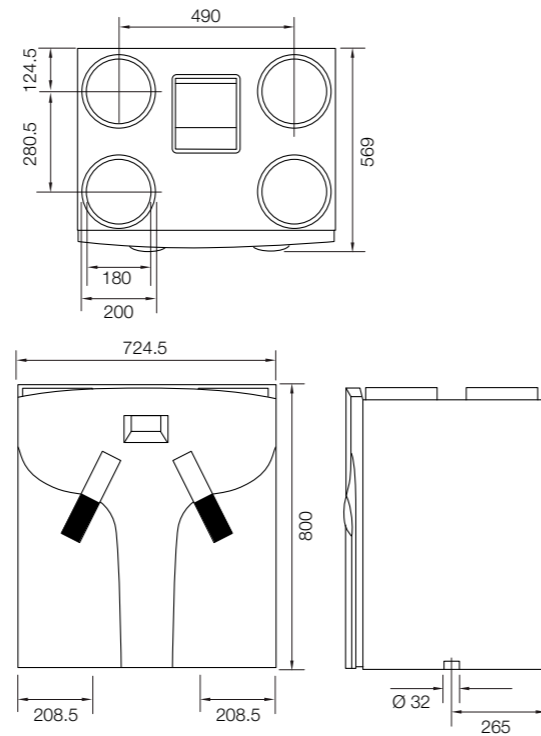
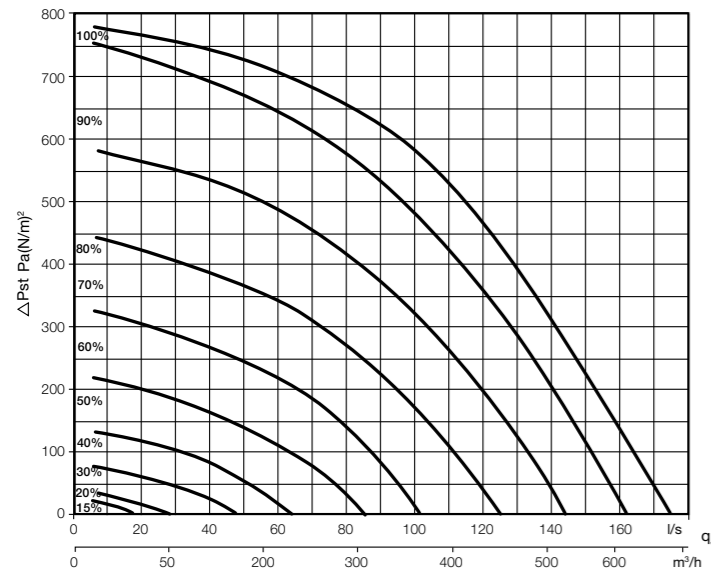

Ancillaries

GD8 Ducting



Flat51 Ducting



Product Specification	
Max House Size EST	280m ² /672m ³
Case Size in mm (W x D x H)	724.5 x 569 x 800
Weight	47kg
Airflow in free air (l/s)	70 – 170
Noise dB(A)	36 - 79
Power (Watts)	13 – 365
Specific Fan Power (W/l/s)	0.78 – 0.93 (0.80)
Spigot Size ID	180mm
Filters	G4 standard/EU7/F7 filters optional
Heat efficiency	87 – 89 (85%)
Summer bypass/Frost protection	Yes/Yes
Enthalpy Heat Exchanger	Optional
Pre-heater	Optional
Condensate Drain ID	32mm

Electrical Specification	
Consumption	230V ~ 50Hz Class I Trickle – 21W, Medium – 44W, Boost – 105W
Wiring	Must comply with IEE or local wiring regulations
Fuse	Standard Model – 3 amp (when fan is supplied from a 6A lighting circuit no local fuse is required). Luxe Model – 6 amp

ComfoCool Model

Features

- Can achieve a maximum cooling output of 2.3kW at an air supply of 500m³/hr (CA550)
- Suitable for use with 'Luxe' version of the CA350 and CA550
- Grade G3 dust filters

ComfoCool with CA350

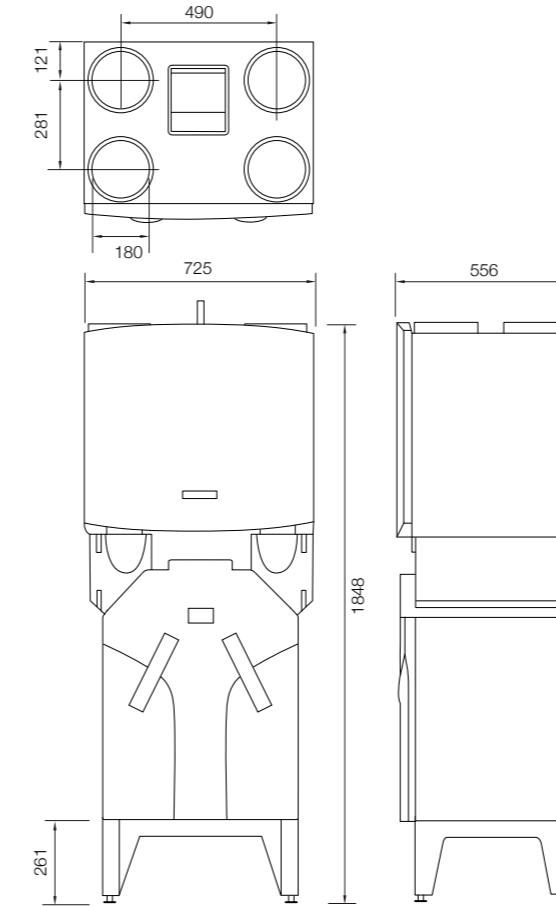

ComfoCool with CA550

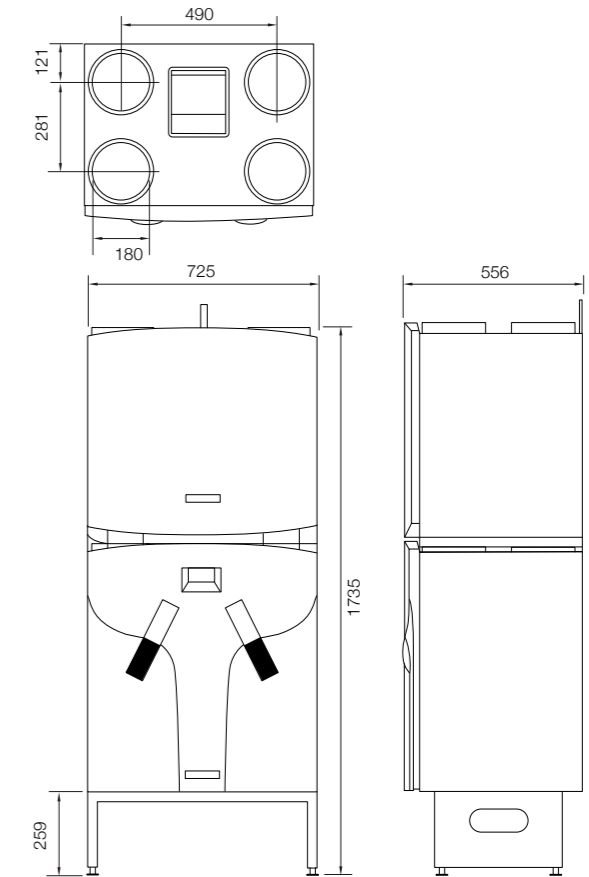

Product Specification	
Case Size in mm (W x D x H)	733 x 556 x 677
Weight	45kg
Duty (l/s)	100 (minimum) – 170
Noise dB(A)	47 - 77
Spigot Size ID	180
Filters	G3 standard
Cooling capacity	1.8 – 2.3kW
Condensate Drain ID	32mm
Coolant	R134a
COP	2.2 – 3

Electrical Specification	
Consumption	230V ~ 50Hz Class I
Wiring	Must comply with IEE or local wiring regulations
Fuse	13 amp

Zehnder Comfosystems – Services and Support

Like our products, our support package is also fully integrated. We aim to weave together the requirements of both the homeowner and the installer throughout all elements of design, installation and after sales support to give you a service which exceeds your expectations.

Consultation, Design and Support

Our network of accredited partners undergo comprehensive training. This allows them to design effective and economical solutions in line with the Best Practice requirements for your build standard. By working with an accredited partner, you can be confident that you are dealing with people who understand the scope of the range and the technology and can give you added value.

Supply

Once your order has been placed, we will orchestrate the safe and timely supply of both your systems and ancillaries to site taking into account the needs of both the build plan and the installer.

Approved Installer Scheme

Our network of installers undergo rigorous training in order to attain their 'Approved Installer' status. By using someone with this status, you can be confident in the quality of the installation, ensuring that performance is optimised and as per the specification.

Onsite Support for Installers

As well as developing comprehensive and easy to follow instructions, we are available to come to site to support installers and ensure that it gets done right first time. This can extend to commissioning the systems so we can ensure that they deliver on both performance and comfort.

Post Installation Support

If, for any reason, you encounter a problem with your installation, we are available to offer advice and support whether this is over the telephone or face to face.

There is no 'one size fits all' solution. We treat everything as an individual project and make sure that it is fully tailored to a suit a household's requirements. It is not our aim to just be a supplier of parts, but a provider of integrated systems... For Eco Home Living.



Zehnder Group

Based in Switzerland and with over 100 years experience in the production of radiators and 40 years in ventilation technology, Zehnder is a complete solution provider for heating cooling and fresh air around Europe. Today, Zehnder has factories on three continents and manufactures to the highest standards to ensure quality, comfort and satisfaction for all of its customers.



Zehnder Comfosystems
A division of
Zehnder Group UK Ltd

Unit 1, Brookside Avenue
Rustington
West Sussex
BN16 3LF

Tel. 01903 777333
Fax. 01903 782398
technical@comfosystems.co.uk
www.comfosystems.co.uk

The Zehnder logo is written in a bold, red, sans-serif font. The letters are slanted upwards from left to right, giving it a dynamic, forward-leaning appearance.